

## Cage Nut

**Thread Type:** Metric - Coarse

**Thread Direction:** Right Hand

**Material:** Stainless Steel

**Class Grade:** A2-70 G304

**Corrosion Protection Level:** Excellent

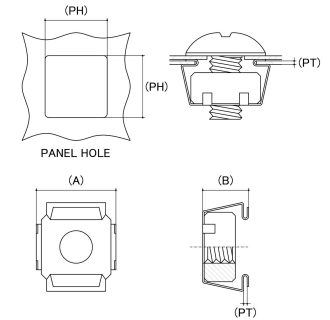

CAD drawings shown for graphic representation only.\*

Size	Thread Pitch (mm)	Thread Type	Overall Nut Height (B) (mm)	Nut Length (L) (mm)	Nut Width (A) (mm)	Panel Thickness (PT) (mm)		Panel Hole Size (PH) (mm)	sku (qfind)
			Nom	Nom	Nom	Min	Max	Nom	
M5	0.80	Coarse	8.70	13.00	13.20	0.70	1.60	9.50	41CNS5
M5	0.80	Coarse	9.80	13.00	13.20	1.70	2.70	9.50	41CNS52
M6	1.00	Coarse	8.80	13.00	13.20	0.70	1.60	9.50	41CNS6
M6	1.00	Coarse	9.50	13.00	13.20	1.60	2.65	9.50	41CNS62
M6	1.00	Coarse	10.20	13.00	13.20	2.65	3.25	9.50	41CNS63
M8	1.25	Coarse	9.70	16.20	16.40	0.70	1.60	12.80	41CNS8
M8	1.25	Coarse	10.70	16.20	16.40	1.80	2.65	12.80	41CNS82
M8	1.25	Coarse	11.10	16.20	16.40	2.65	3.25	12.80	41CNS83
M10	1.50	Coarse	11.60	16.20	16.40	2.65	3.25	12.80	41CNS10

**Disclaimer:**

Dimensional data and technical information was obtained from publically available sources and not acquired through standard agencies. It has been completed and compiled for reference purposes only; where discrepancies are found they are subject to change without notice. Bolt & Nut Australia makes no warranties or representations regarding the accuracy and validity of the compiled information and data. Contact the relevant standard authorities for accurate and detailed information.

\* CAD drawings may not reflect diameter, thread length or overall length.

© Bolt & Nut Australia Pty Ltd. All rights reserved.

Version: 18 Mar 2024